

Dacomobile – Seitliche Ablage

Dacomobile trolley – Side shelf

Poste mobile Dacomobile – Plateau latéral

Assembly Instructions

1 Allgemeine Hinweise

Weitere Dokumentation beachten



Achtung!
User Manual „Gerätewagen“ und
Montageanleitung „Dacomobile –
Grundgestell“ unbedingt beachten.

Gültigkeit

Diese Anleitung gilt für folgende Geräte-
wagen-Komponenten der Knürr AG:

- Dacomobile seitliche Ablage,
rechts oder links

Notwendiges Werkzeug

- Innensechskantschlüssel 5 mm
- Kreuzschlitzschraubendreher

General information

Refer to the other documentation

Warning
See user manual entitled “Mobile
workstations” and assembly instruc-
tions “Dacomobile trolley – Base
frame”.

Validity

These instructions apply to the following
trolley components from Knürr AG:

- Dacomobile side shelf,
right or left

Tools required

- 5 mm Allen key
- Philips screwdriver

Consignes générales

Respecter les indications ci-dessous

Attention !
Respecter impérativement le manuel
utilisateur « Postes mobiles » et les ins-
tructions de montage « Poste mobile
Dacomobile – Châssis de base ».

Validité

Ce mode d’emploi est valable pour les
éléments de postes mobiles de Knürr AG
suivants :

- Plateau latéral du Dacomobile,
côté droit ou côté gauche

Outils nécessaires

- Clé Allen 5 mm
- Tournevis cruciforme

2 Montage

Dargestellt ist die Montage der seitlichen
Ablage rechts, Montage links erfolgt analog.

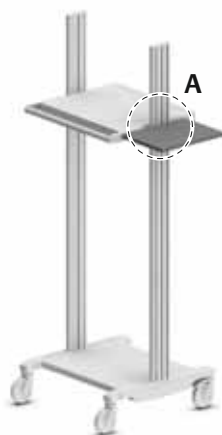

Installation

The figure shows the side shelf fitted on the
right. It can be fitted on the left in exactly
the same way.

Montage

Le schéma montre le montage du plateau
latéral du côté droit ; le montage du côté
gauche s’effectue de manière analogue.

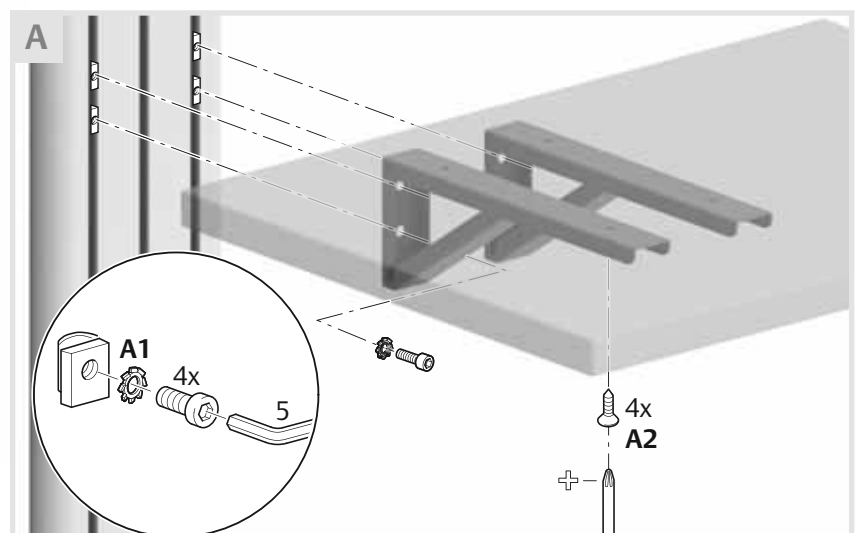

Nur für ESD-Version:

- Zahnscheibe A1 verwenden.
- Bei der Befestigung der Ablageplatte A2 auf das passende Lochbild für Dacomobile achten.

For ESD version only:

- Use washer A1.
- When fastening the shelf plate A2, check the appropriate hole pattern for Dacomobile.

Uniquement sur la version ESD :

- utiliser une rondelle dentée A1.
- Lors de la fixation du plateau A2, veiller à disposer des perforations adaptées au Dacomobile.

3

Maximale Beladung



Gefahr!

Maximale Beladung der seitlichen Ablage beachten: 10 kg
Maximale Gesamtbeladung des Dacomobiles beachten: 210 kg

Maximum load

Danger

Do not exceed the maximum load of the side shelf: 10 kg
Do not exceed the maximum load of the Dacomobile: 210 kg

Charge maximale

Danger !

Respecter la charge maximale du plateau latéral : 10 kg
Respecter la charge maximale du Dacomobile : 210 kg

While every precaution has been taken to ensure accuracy and completeness in this literature, Knürr AG assumes no responsibility, and disclaims all liability for damage resulting from use of this information or for any errors or omissions.

©2008 Knürr AG. All rights reserved throughout the world. Specifications subject to change without notice.

All names referred to are trademarks or registered trademarks of their respective owners.

©Knürr and the Knürr logo are registered trademarks of Knürr AG.

Knürr
Technical Furniture GmbH
Business Unit

Hauptstraße 35
 94439 Münchsdorf • Germany
 Tel. +49 (0) 87 23/28-0
 Fax +49 (0) 87 23/28-138
 www.technical-furniture.com

Knürr AG
Global Headquarters

Mariakirchener Straße 38
 94424 Arnstorf • Germany
 Tel. +49 (0) 87 23/27-0
 Fax +49 (0) 87 23/27-154
 info@knuerr.com
 www.knuerr.com

Emerson Network Power

The global leader in enabling business-critical continuity

EmersonNetworkPower.com

Knürr logo, Emerson Network Power and the Emerson Network Power logo are trademarks and service marks of Emerson Electric Co. ©2008 Emerson Electric Co.